

Sampling pump 5000 ml/min

OP50

The OP50 dust sampler has been designed to be a robust instrument, offering stable, reliable and accurate sampling thanks to its flow measurement and control technology.

Its large touch screen allows a simple, easy and comfortable use.

OP50 can be used as a pump for personal sampling, such as indoor air or environmental monitoring or epidemic prevention. It can be used by prevention workers, control laboratories, research institutes, to collect any type of gas or aerosols (organic, inorganic, etc.).



Main characteristics

- Flow rate range: 1000ml/min to 5000ml/min.
- Complies with ISO13137 standard.
- High flow stability due to real-time compensation of temperature and atmospheric pressure.
- Compensation of pressure drop greater than 4kPa at a flow rate of 5000 ml/min.
- Sampling modes: manual / fixed time / fixed volume.
- Continuous data recording and sampling report generation.
- Easy to use thanks to its intuitive interface and backlit OLED display.
- Lightweight.
- Protection: IP54.

Main features

Flow range	1-5 l/min
Flow range	Better than +/- 3% FS
Pressure drop compensation	30kPa at 2 l/min 20kPa at 3 l/min 10kPa at 4 l/min 4kPa at 5 l/min
Working condition	-10 at +40°C / 0 at 95°C RH (25°C)
Storage condition	-10 at +50°C / 0 at 95°C RH, non-condensed
Battery type	7.4V Li-polymer battery
Autonomy	> 8h continuously at 5 l/min
Charging time	≤ 5h
Weight and dimensions	450g, 130x60x99mm
Interface	Intuitive interface and backlit OLED display
Data	Continuous data recording Sampling report editing
Sampling modes	Manual / fixed duration / fixed volume
Protection	IP54

Dimensions

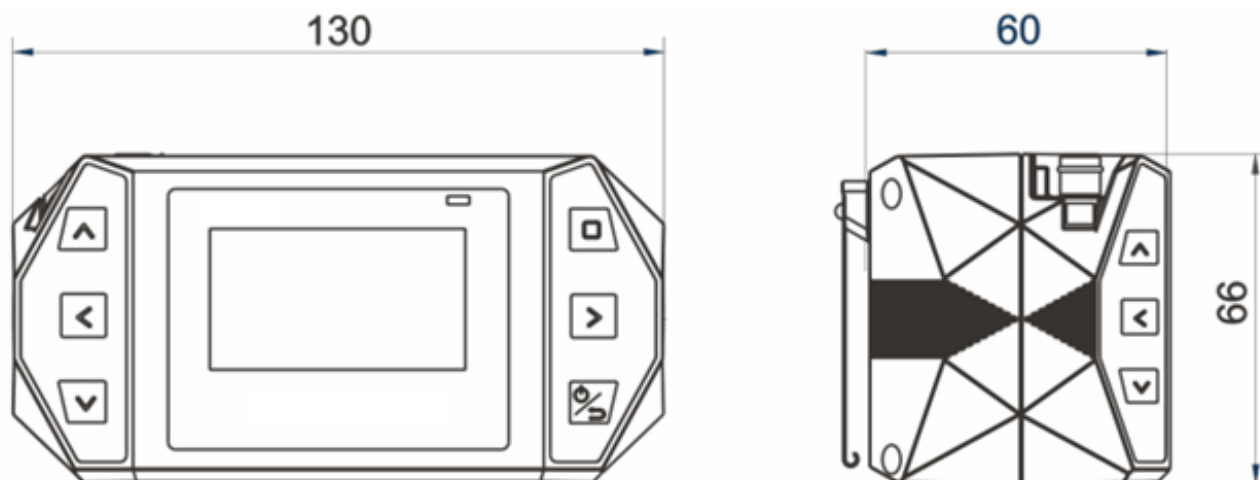

Technical specifications may change without previous warning